

MODEL : DN-50W
DIGITAL INDICATOR

USER MANUAL

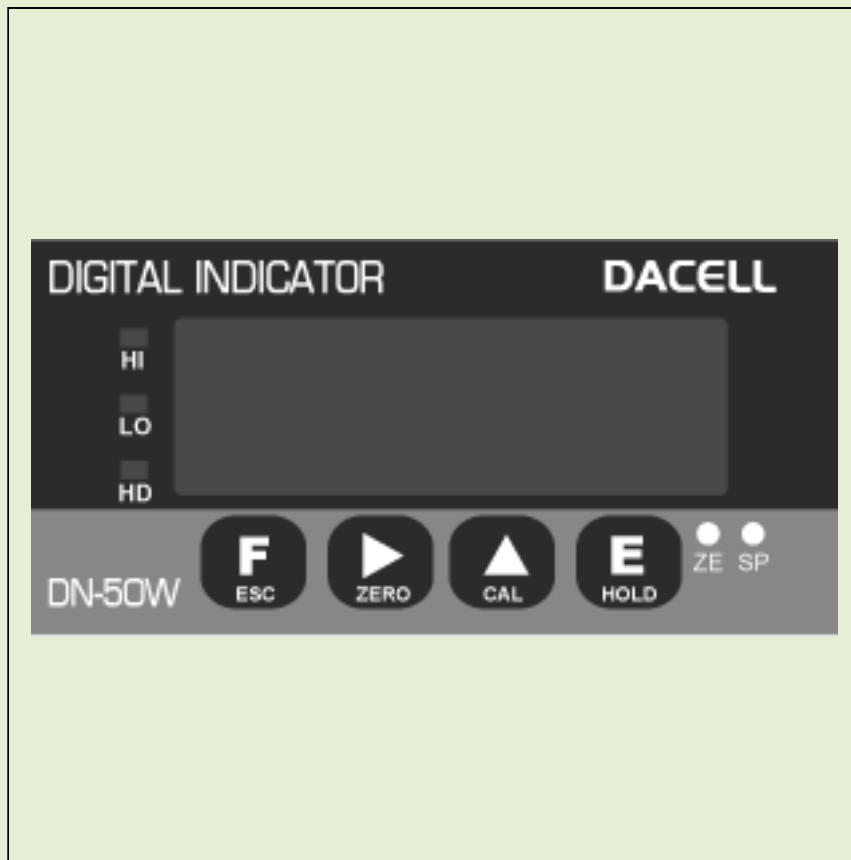

DACELL CO.,LTD.

Address : 681-1 Cheoksan-Ri, Nami-Myeon, Cheongweon-Gun, Chung-buk

TEL :82-43-260-2242

FAX : 82-43-260-2245

<http://www.dacell.com>

E-Mail : info@dacell.com

Contents

1. Sepcial Features	2
1-1. High-speed conversion method	2
1-2. Calibration method	2
1-3. HOLD & PEAK HOLD	2
1-4. Comparison Output	2
1-5. Data Back-up	2
1-6. Watch dog	2
1-7. Option	3
1-8. Power	3
2. Attention	4
2-1. Attention for installation	4
2-2. Attention for use	4
3. Specification	5
4. Front Panel	6
5. Rear Panel	7
6. Wiring Diagram.....	9
7. Components & Function	10
7-1. Flow Chart	10
7-2. How to use Hold mode	11
7-3. How to use comparison output function	12
8. Setting mode	14
8-1. Types of Setting mode & Set-up	14
8-2. Function mode (Function Set-up)	15
8-3. Digital calibration (Calibration by sensor output value)	22
8-4. Real-weight Calibration	23
8-5. Calibration by Shunt CAL value	24
8-6. Data Back-up & Restore	25
8-7. Lock Set-up.....	26
9. Product Inspection	27
10. OPTION (OP-02, OP-03)	
Option 02 (RS232C)	28
Option 03 (RS485)	30

1. Special Features

We thank you for using our product. Please refer to this manual or contact our office if you find any problems during using our product.

This product is an indicator that amplifies the micro voltage signals from each sensor and display in digital. It is mainly used to measure physical quantities of the items using strain gauge such as loadcell, pressure sensor, displacement sensor and torque sensor.

This product has the following special features.

1-1. High-speed Conversion Method

24bit High-speed A/D converter that can detect the sensor's input signal at a rate of 1000times per second is used. For analog output, 16bit D/A converter with 1000times per second is used so that there is almost no deviation between display value and output value.

1-2. Calibration Method

2 types of calibration systems are adopted. Calibration by actual load (standard weight) and calibration by rated output of sensor (mV/V).

1-3. Hold and Peak Hold

You can choose Analog peak hold (High-speed) or Digital peak hold (Low-speed) as per your need.

1-4. Comparison Output

You can do set-up the maximum and lower limit value by the keys on the front panel and output contact point signal of the rear panel.

1-5. Data Back-up

All the set-up values will be memorized on the flash memory so the inputted data can be saved and no need to do the re-setting even in case of the interruption of the electric power or power disconnection.

1-6. Watch dog

This function is for automatic reset in case the system is stopped due to the external factors such as noise.

1-7. Option

You can use RS232C, RS485 and 4 relay output as the optional specification.

1-8. Power

AC 85 ~ 265V 50/60Hz Free voltage

2. Attention

For the efficient and safe use, please carefully read and be fully aware of the following details before using this product.

It is strictly forbidden to use this product for any other purpose of use or to attempt to make any alteration on this product.

2-1. Attention for installation

- Please keep it out of wet places.
- Do not set it up near vibration & impulse, high temperature and humidity.
Keep it out of the direct rays of the sun. Set it up where there is less dust, and Keep it out of direct air including salt and ion.
- Do not use when there is inflammable gas or heavy machinery, and smog.
- Ground earth-terminal (⊕).
- Make wire separately from power system wiring and noise wiring.
- Make sure the use of 4 line sealed cable as a sensor cable. Too long cable leads to measurement error due to wiring resistance (around 10meters).

2-2. Attention for use

During calibration, Do not input free-load state and real-weight load until it becomes stable. Pressing Enter Key in unstable condition leads to calibration error.





Do not press any Key in use at one's discretion. Please refer to 7. Setting-up mode for the function and method of Key.

3. Specification

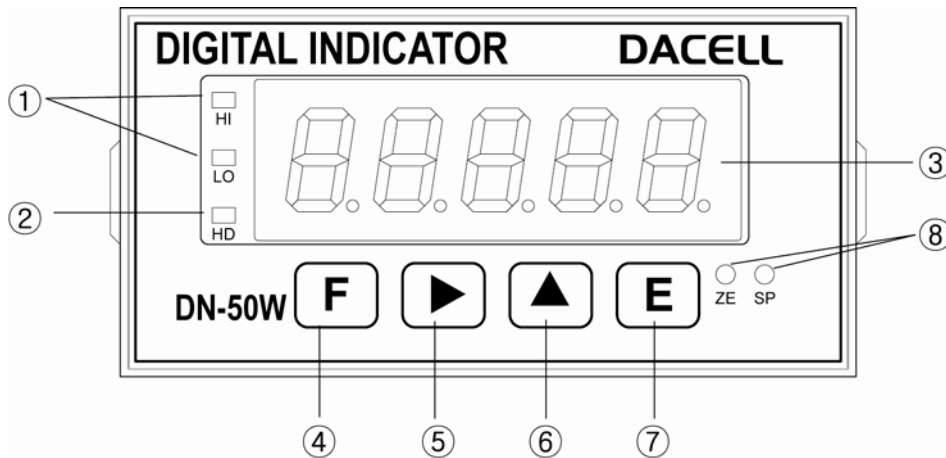
- Available sensor : Strain Gauge sensor (Bridge 120Ω, 350Ω, 700Ω)
- Upper limit Display : -19999 ~ +99999
- A/D Converter : 24bit, 1000 times/sec
- D/A Converter : 16bit, 1000 times/sec
- Temperature Characteristic (Amp Characteristic)
 - Zero : 0.5μV/°C
 - Span : 50ppm/°C
- Front Panel
 - Measured value display : 7 segment 5 Digit, Character Height 14mm
 - Status display : Red LED 3 pcs
 - Key Switch : 4 pcs
- Output
 - Comparison output: Upper limit(HI), Lower limit(LO), Normal(OK) Output
Contact Capacity – AC 125V 0.5A/ DC 24V 1A
 - Analog Output : DC 0~10V/4~20mA (Optional at the time of order)
- Temperature range for use: -10°C~ 60, >82% RH (No dewing)
- External dimension : 96 × 48 × 128 mm (W × H × D)
- Panel cutting size : 91 × 45 mm
- Weight : About 450g
- Power Supply : AC 85 ~ 265V, 50/60Hz
- Option : 4~20mA(OP-1), RS232C (OP-02), RS485 (OP-03)

4. Front Panel





- ① HI, LO Indication LED : Hi or LO LED will be lighted when measured value exceeds the setting value.
- ② HOLD indication LED : This LED will be lighted when the measured value is on Hold.
- ③ Measured value Indication: It indicates the measured value and each setting value.
- ④ ZERO/SPAN setting up VR
: It is used when ZERO and SPAN calibration of Analog output (DC 0 ~ 10V or 4 ~ 20mA) is carried out.
- ⑤  **F**
Measuring Mode: Once this Key is pressed for more than 1 second, the current measuring value will be Zero (0) and the Analog output will be 0V (4mA) as well.
SET-UP Mode: Once this is pressed on the Function Set-up Mode, you will return to the measuring mode.
- ⑥  **▶**
Measuring Mode: Once this Key is pressed, the lower limit setting value will be displayed and this value also can be changed.
SET-UP Mode: The location of row for the number flickering can be moved.
- ⑦  **▲**
Measuring Mode: Once this Key is pressed, the upper limit setting value will be displayed and the value can be changed.
SET-UP Mode: The flickering number will be increased by 1 and 1.
- ⑧  **E**
Measuring Mode: Once this Key is pressed, HOLD will be selected and once this key is pressed again, HOLD will be cancelled.
SET-UP Mode: Save each set-up value.

5. Rear Panel

Please check the location of terminal and its use. While the projected button is being pressed, please insert the cable into the lower hole completely. As soon as you release the button, the connection will be completed. At the point, please slightly pull the cable and check whether the cable is come off or not.

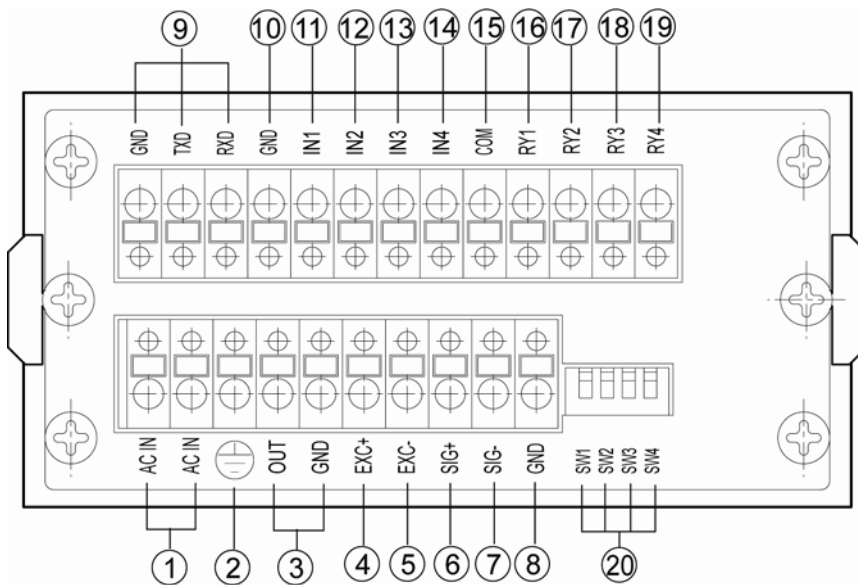
(The most suitable cable is Φ 0.5~1. Linking cable must be brazing or used with 1 terminal)



- ① AC IN : Main Power Supply Wiring Terminal
- ②  : Ground Terminal (as an independent ground connection.)
- ③ OUT : Analog (DC 0 ~10V/DC 4 ~ 20mA) Output Terminal
- ④ EXC+ : Sensor Supply Voltage + Connection Terminal
- ⑤ EXC- : Sensor Supply Voltage + Connection Terminal
- ⑥ SIG+ : Sensor Output Signal + Connection Terminal
- ⑦ SIG- : Sensor Output Signal - Connection Terminal
- ⑧ GND : SHIELD connection terminal of sensor
- ⑨ GND, TXD, RXD : RS232C SERIAL INTERFACE (RS485 : TXD → TX+, RXD → TX-)
- ⑩ GND : External Input Common Terminal
- ⑪ IN1 : External HOLD Input Terminal
- ⑫ IN2 : External ZERO Input Terminal
- ⑬ IN3 : External printer signal Input Terminal (when PT-100 use)
- ⑭ IN4 : No use

- ⑮ COM : RELAY Output Common Terminal
- ⑯ RY1 : RELAY 1(Lower Limit) Output Terminal
- ⑰ RY2 : RELAY2 (Upper Limit) Output Terminal
- ⑱ RY3 : RELAY3(Normal) Output Terminal (OK)
- ⑲ RY4 : RELAY 4 Output Terminal
- ⑳ ANALOG OUT LOW PASS FILTER (10Hz, 100Hz, 1 kHz) Selet Switch
 - SW1 : 10Hz
 - SW2 : 100Hz
 - SW3 : 1kHz

◀Attention▶

1. When wiring, please pull out the power plug. (Main power supply)
2. Please use the thick calbe for ground terminal (⊕) so that you can avoid any trouble due to the impulse voltage or surge. If possible, please keep it as an independent ground.
(This must be used in the area with heavy noise. If the ground is made with other device, it will be affected by noise.)
3. Please check the function of the terminal before you do the wiring so that you can prevent any malfunction in advance.
4. Manufacture will be relieved of its responsibility for any damge or injury due to the disassembly and alteration made without any agreement. Also, no A/S will be made.

6. Wiring Diagram

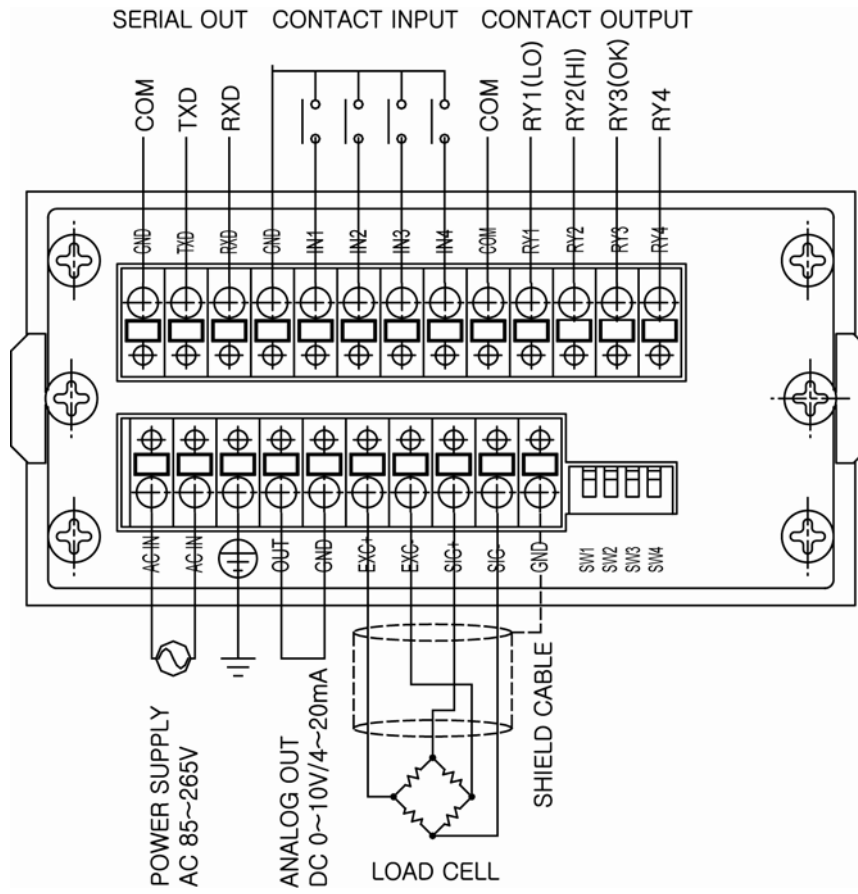

<Wiring Diagram>

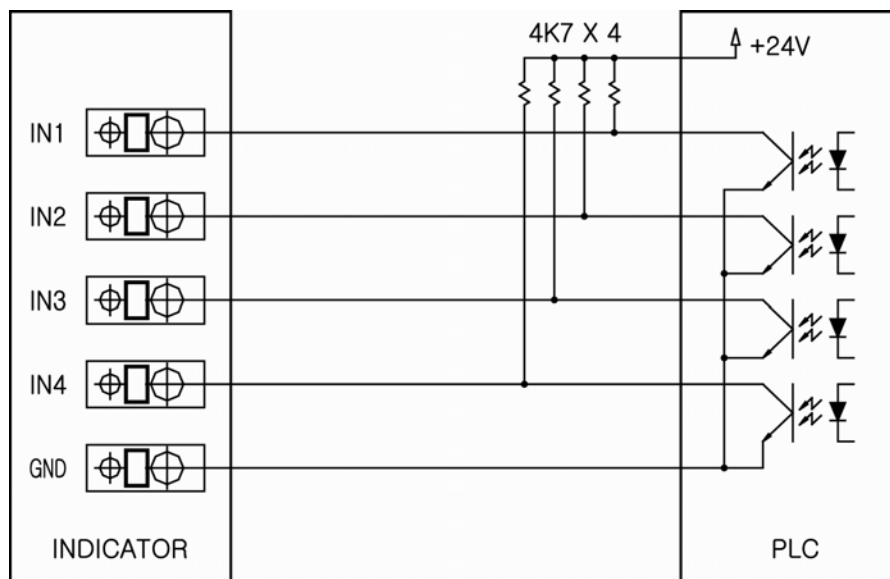

<Example - External Input PLC Connection>

7. Components & Function

7-1. Flow Chart

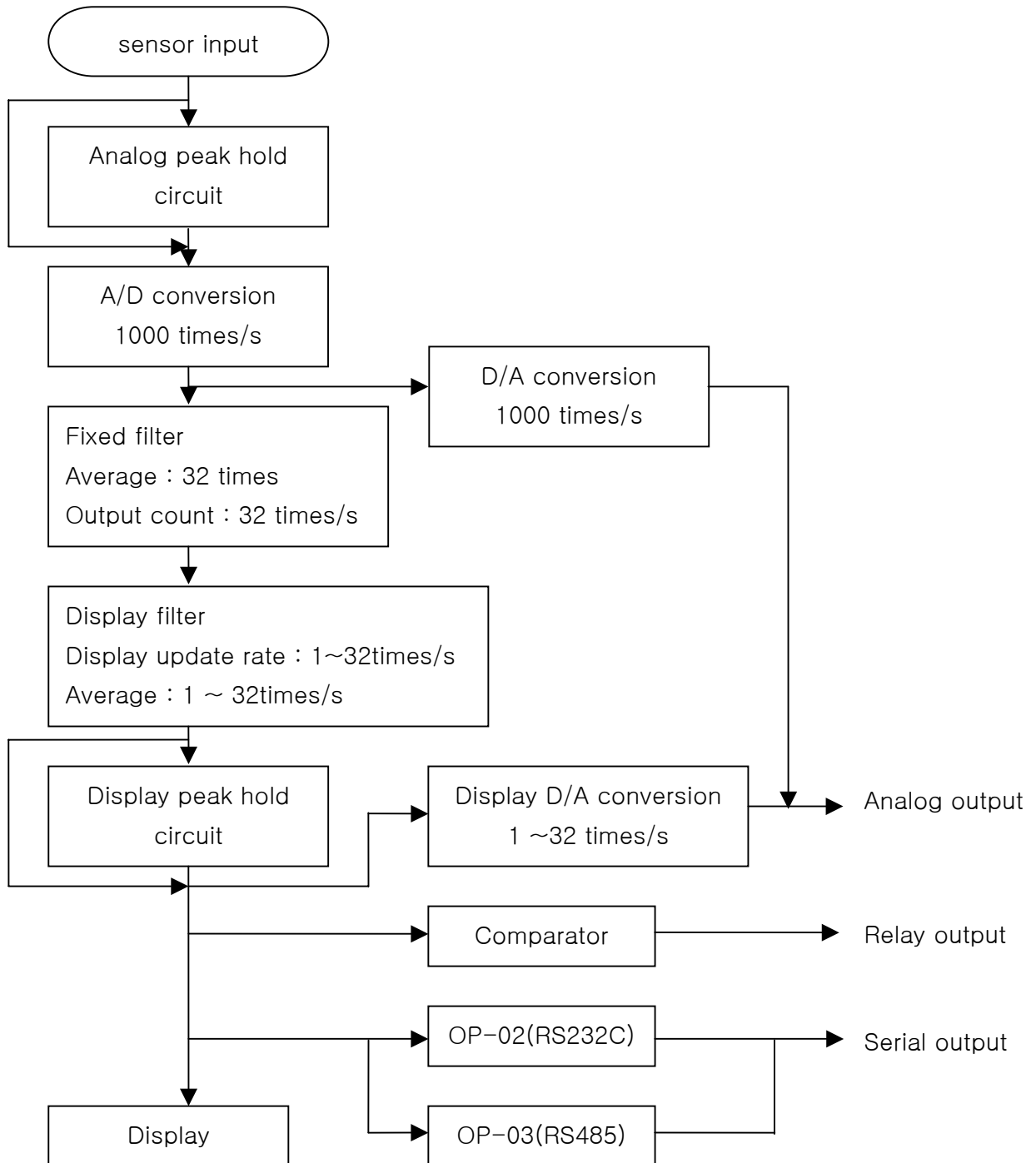

7-2. How to use Hold mode

Hold mode is largely divided into Peak Hold and Sample Hold. Please select Analog, Digital or Display Hold as per your purpose of use (Hi or Low Speed)

To input Hold, you can use Hold key on the front panel or external input. For the operation method, please refer to the drawing below.

1) Peak Hold : To Hold the maximum value among the measured values.

Analog peak hold mode : It is a high-speed Peak hold. It is to hold and display the maximum value of (+) direction.

Display peak hold mode : It is a low-speed Peak hold. It is to hold and display the maximum value of (+) direction.

Absolute peak hold mode : It is a low-speed Peak hold. It is to hold and display the maximum value of the absolute value (+/-).

2) Sample hold : It is to hold and display the value at the time of Hold signal input among the measured values.

Digital sample hold mode : It is operated by high-speed sample hold.

Display sample hold mode : It is operated by low-speed sample hold.

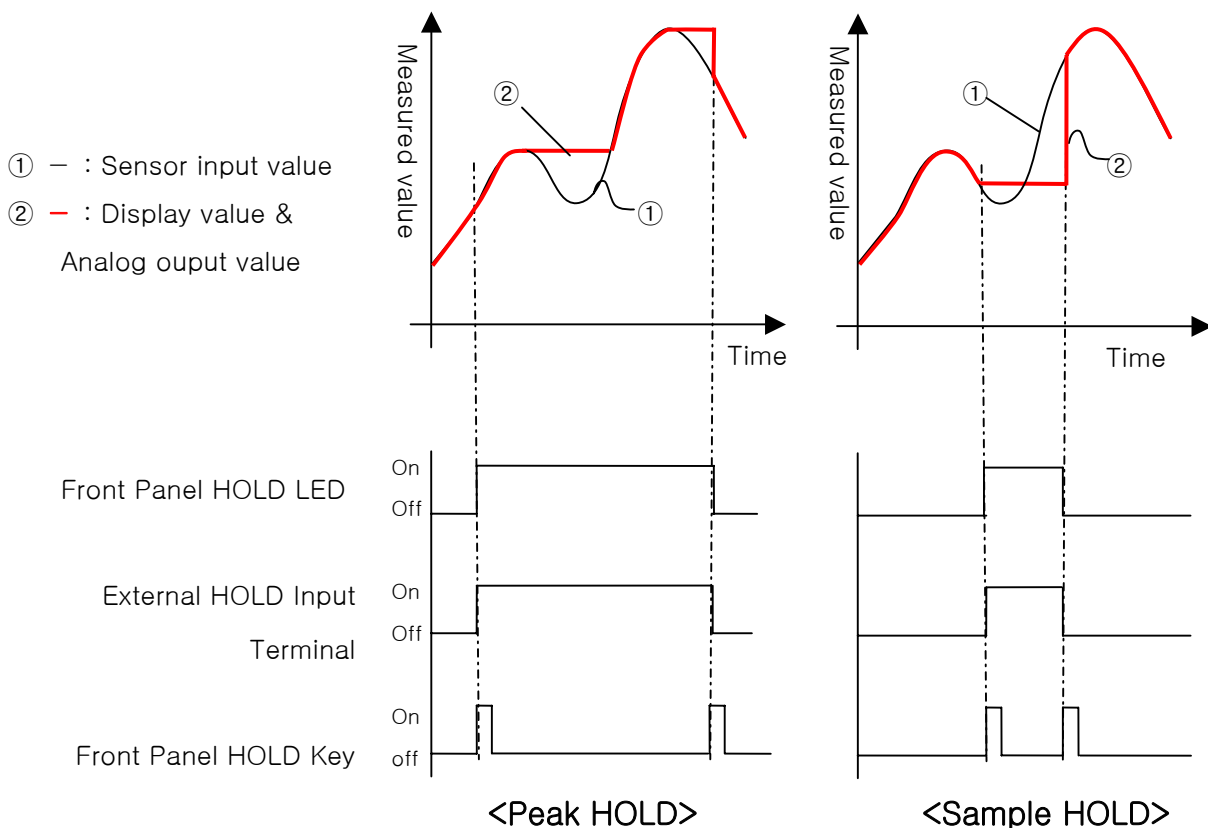

7-3. How to use comparison output function

For comparison output function, there are 3 different modes such as Decision, High limit, Low limit. It displays through the relay of rear panel comparing each setup value. On High limit and Low limit mode, Hysteresis can be used.

To set up upper limit (High) and lower limit(Low), please use the key on the front panel.

- 1) Decision mode :
Measured Value \leq Lower limit setup value \Rightarrow RY1 ON (HI)
Measured Value \geq Upper limit setup value \Rightarrow RY2 ON (LO)
Lower limit setup value $<$ Measured value $<$ Upper limit setup value \Rightarrow RY3 ON (OK)
- 2) High limit mode :
Measured Value \geq RY1 setup value \Rightarrow RY1 ON
Measured Value \geq RY2 setup value \Rightarrow RY2 ON
Measured Value \geq RY3 setup value \Rightarrow RY3 ON
Measured Value \geq RY4 setup value \Rightarrow RY4 ON
Measured Value $<$ RY1 setup value - Hysteresis value \Rightarrow RY1 OFF
Measured Value $<$ RY2 setup value - Hysteresis value \Rightarrow RY2 OFF
Measured Value $<$ RY3 setup value - Hysteresis value \Rightarrow RY3 OFF
Measured Value $<$ RY4 setup value - Hysteresis value \Rightarrow RY4 OFF
- 3) Low limit mode :
Measured Value \leq RY1 setup value \Rightarrow RY1 ON
Measured Value \leq RY2 setup value \Rightarrow RY2 ON
Measured Value \leq RY3 setup value \Rightarrow RY3 ON
Measured Value \leq RY4 setup value \Rightarrow RY4 ON
Measured Value $>$ RY1 setup value + Hysteresis value \Rightarrow RY1 OFF
Measured Value $>$ RY2 setup value + Hysteresis value \Rightarrow RY2 OFF
Measured Value $>$ RY3 setup value + Hysteresis value \Rightarrow RY3 OFF
Measured Value $>$ RY4 setup value + Hysteresis value \Rightarrow RY4 OFF
- 4) Low & High limit mode
Measured Value \leq RY1 setup value \Rightarrow RY1 ON
Measured Value \leq RY2 setup value \Rightarrow RY2 ON
Measured Value \geq RY3 setup value \Rightarrow RY3 ON
Measured Value \geq RY4 setup value \Rightarrow RY4 ON
Measured Value $>$ RY1 setup value + Hysteresis value \Rightarrow RY1 OFF
Measured Value $>$ RY2 setup value + Hysteresis value \Rightarrow RY2 OFF
Measured Value $<$ RY3 setup value - Hysteresis value \Rightarrow RY3 OFF
Measured Value $<$ RY4 setup value - Hysteresis value \Rightarrow RY4 OFF

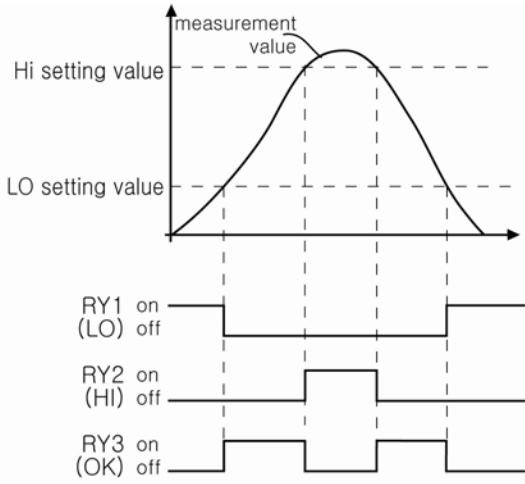

<Decision mode>

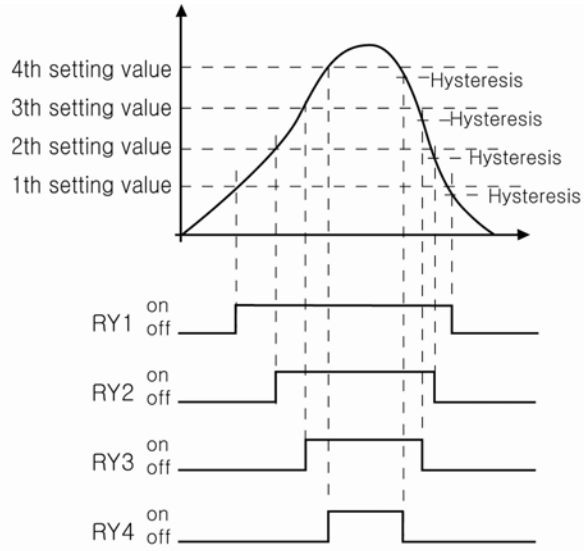

<High limit mode>

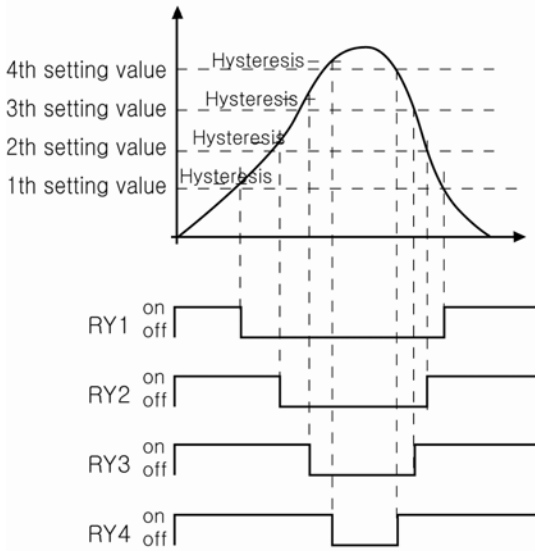

<Low limit mode>

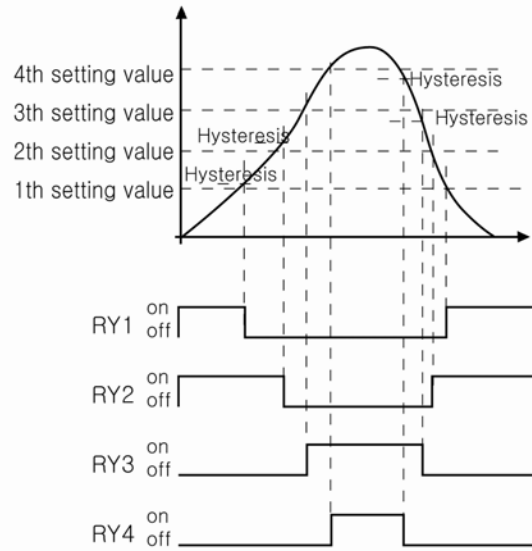

<Low & High limit mode>

8. Setting Modes

8-1. Types of Setting mode & Set-up

For Setting mode, there are 3 different types of mode such as Function mode, Digital calibration mode and Actual load calibration mode.

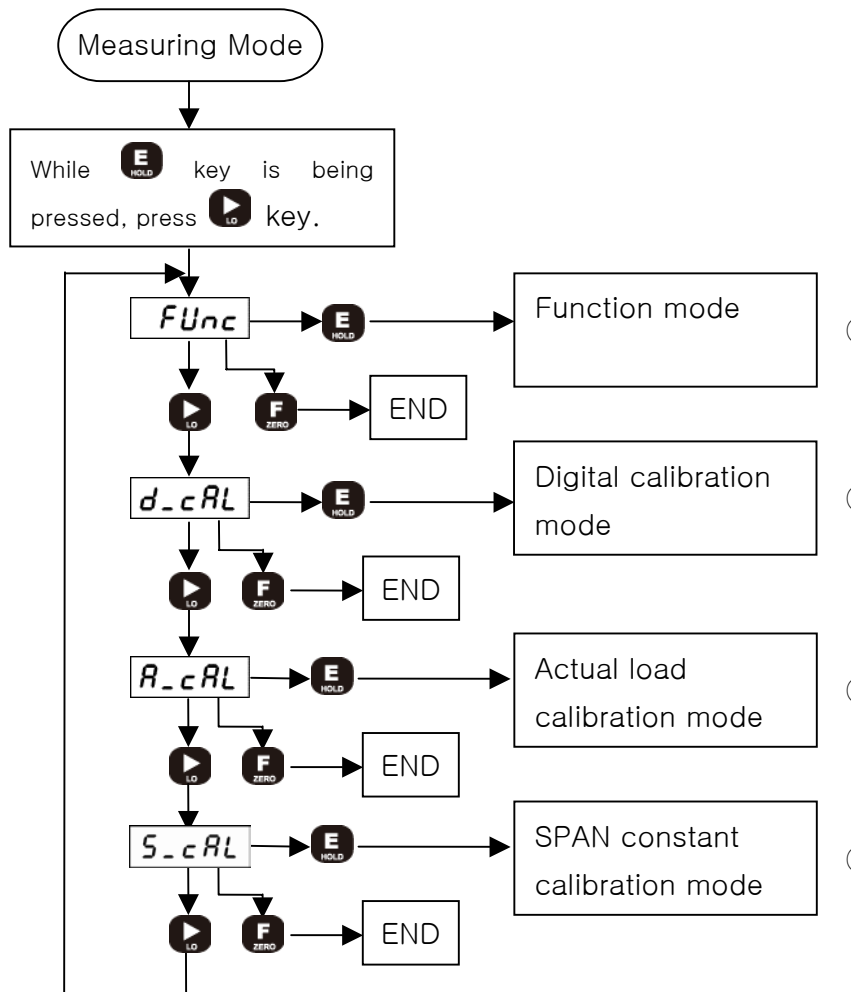

- ① Function mode: Access to each function setup mode. Please refer 8-2 Function Mode.
- ② Digital calibration mode: It is to calibrate into the sensor's output value. No need to prepare for the actual load (standard weight). Please refer 8-3 How to calibrate.
- ③ Actual load calibration mode: It is to calibrate by adding the actual load (Standard weight or the load you know). Please refer 8-4 How to calibrate.
- ④ SPAN constant calibration mode: It is to calibrate with the S.CAL value written down for load calibration. Please refer 8-5 How to calibrate.

8-2. Function mode

1) How to set function.

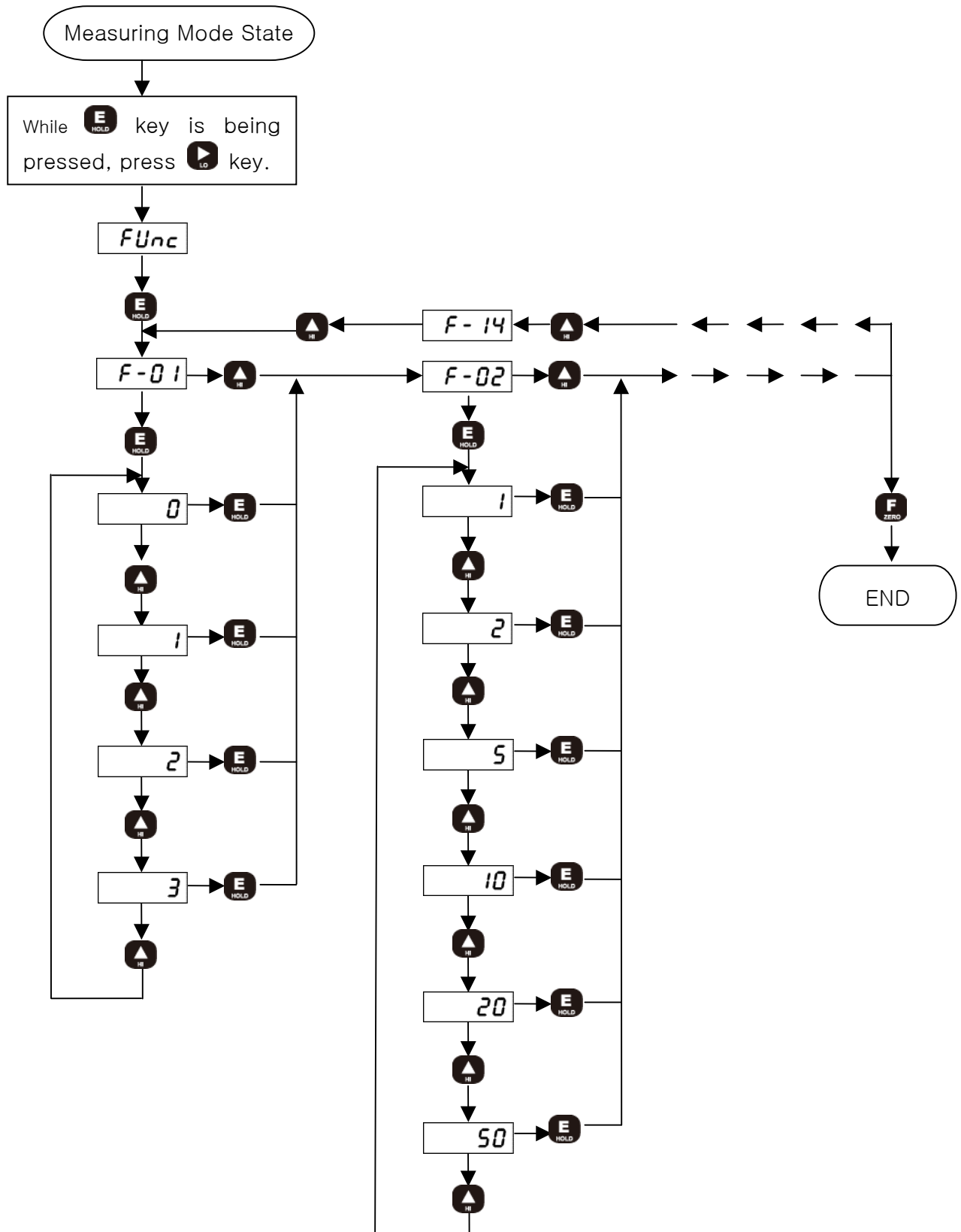

2) How to set RELAY data

① Decision mode (Decision mode : mode 0)

② Limit mode (Low & High limit mode: mode 1 ~ 3)

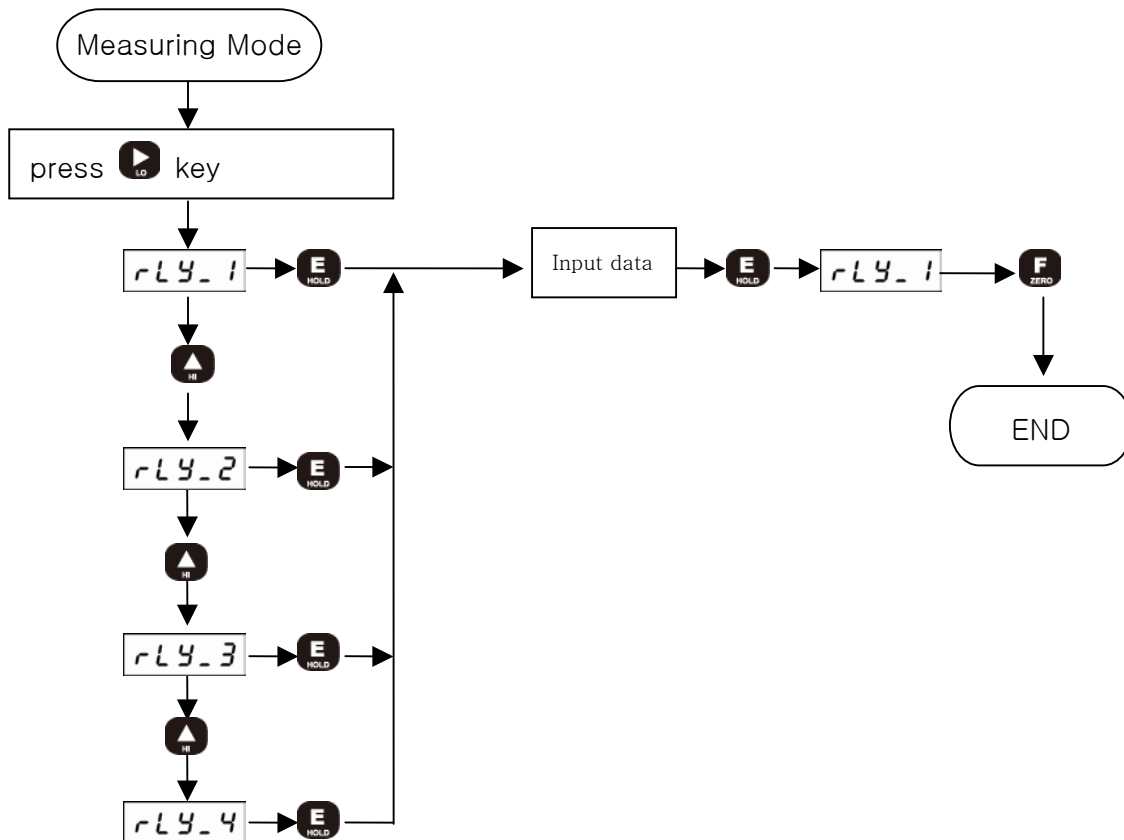

Function mode list

Name	Function	Setting	The standard set-up value at the time of delivery from the factory
F-01	Decimal point	0, 1, 2, 3	1
F-02	Division	1, 2, 5, 10, 20, 50	1
F-03	Display filter	0, 4, 8, 16, 32	8
F-04	Hold mode	Display SH, Digital SH, Display PH(+), Absolute PH(\pm), Analog PH(+)	Display PH(+)
F-05	Comparison mode	Decision, High limit, Low limit	Decision
F-06	Hysteresis	0 ~ 99	0
F-07	DAC mode	Display DAC, High speed DAC	Display DAC
F-08	DAC capacity	-19999 ~ +99999	10000
F-09	ID Number	0 ~ 32	0
F-10	Baud rate	2400, 4800, 9600, 19200, 38400, 57600	9600
F-11	Auto zero tracking	0 ~ 99	0
F-12	Auto zero tracking time	0.0 ~ 5.0 sec	0.0
F-13	Force unit	Kg(kg/cm ²), N, lb, bar, MPa	Kg
F-14	Key disabling	Zero key, Lo key, Hi key, Hold key	0000

F-01. Decimal point (Decimal point Set-up)

(Standard setup value : 1)

Display data	Setting
0	00000 : No decimal point
1	0000.0 : One decimal place
2	000.00 : Two decimal places
3	00.000 : Three decimal places

F-02. Division (Minimum display unit setup)

(Standard setup value : 1)

Display data	Setting
1	Displayed In 1 (0, 1, 2, 3, 4 …….)
2	Displayed in 2 (0, 2, 4, 6, 8 …….)
5	Displayed in 5 (0, 5, 10, 15 …….)
10	Displayed in 10 (0, 10, 20, 30 …….)
20	Displayed in 20 (0, 20, 40, 60 …….)
50	Displayed in 50 (0, 50, 100, 150 …….)

F-03. Display filter (Display speed setup)

(Standard setup value : 8)

Display data	Setting
0	No filter
4	Average time 1/8 sec
8	Average time 1/4 sec
16	Average time 1/2 sec
32	Average time 1 sec

F-04. Hold mode

Display data	Setting
0	Display sample Hold : To hold the display value at the time of Hold signal input.
1	Digital sample Hold : To hold the A/D conversion value at the time of Hold signal input.
2	Display Peak Hold : To hold the maximum value of display values during Hold signal input.
3	Absolute Peak Hold : To hold the maximum absolute value of display values during Hold signal input.
4	Analog Peak Hold : To hold the maximum value of sensor input during Hold signal input.

F-05. Comparison mode (Comparison output mode setup)

(Standard setup value : 0)

Display data	Setting
0	Decision mode : Relay RY1(Lo), RY2(Hi), RY3(Ok) Output
1	High limit mode : Relay RY1, RY2, RY3, RY4 output
2	Low limit mode : Relay RY1, RY2, RY3, RY4 output
3	Low & High limit mode : Relay RY1, RY2, RY3, RY4 output

F-06. Hysteresis

(Standard setup value : 00)

Display data	Setting
00 }	00 : Hysteresis – not used
99	01 ~99 : Hysteresis – used (Decision mode is not applied)

F-07. DAC mode (Analog Output mode setup)

(Standard setup value : 0)

Display data	Setting
0	Display DAC mode Convert the current display value and the do the analog output.
1	High speed DAC mode Convert A/D input value and do the analog output.

F-08. DAC capacity (Analog Output value setup)

(Standard setup value : 10000)

Display data	Setting																																			
-19999 }	To setup the rated capacity of analog output																																			
+99999	<p><Example of Setup value and output></p> <table border="1"> <thead> <tr> <th rowspan="2">Setup Value</th> <th colspan="2">Voltage Outupt ($\pm 10V$)</th> <th colspan="2">Current Output (4 ~20mA)</th> </tr> <tr> <th>Display Value</th> <th>Output</th> <th>Display Value</th> <th>Output</th> </tr> </thead> <tbody> <tr> <td rowspan="3">+10000</td> <td>-10000</td> <td>-10V</td> <td>-10000</td> <td>-</td> </tr> <tr> <td>0</td> <td>0V</td> <td>0</td> <td>4mA</td> </tr> <tr> <td>+10000</td> <td>+10V</td> <td>+10000</td> <td>20mA</td> </tr> <tr> <td rowspan="3">-10000</td> <td>-10000</td> <td>+10V</td> <td>-10000</td> <td>20mA</td> </tr> <tr> <td>0</td> <td>0V</td> <td>0</td> <td>4mA</td> </tr> <tr> <td>+10000</td> <td>-10V</td> <td>+10000</td> <td>-</td> </tr> </tbody> </table>	Setup Value	Voltage Outupt ($\pm 10V$)		Current Output (4 ~20mA)		Display Value	Output	Display Value	Output	+10000	-10000	-10V	-10000	-	0	0V	0	4mA	+10000	+10V	+10000	20mA	-10000	-10000	+10V	-10000	20mA	0	0V	0	4mA	+10000	-10V	+10000	-
Setup Value	Voltage Outupt ($\pm 10V$)		Current Output (4 ~20mA)																																	
	Display Value	Output	Display Value	Output																																
+10000	-10000	-10V	-10000	-																																
	0	0V	0	4mA																																
	+10000	+10V	+10000	20mA																																
-10000	-10000	+10V	-10000	20mA																																
	0	0V	0	4mA																																
	+10000	-10V	+10000	-																																

F-09. ID Number (Communication Device Number setup)

(Standard setup value : 00)

Display data	Setting
00 }	00 : Device number is not set-up (Stream mode : always transmit data)
32	01 ~32 : Device number is set-up (Command mode : Transmit data by command)

F-10. Baud rate (Communication Speed Setup)

(Standard setup value : 9.60)

Display data	Setting	Stream mode	Command mode
2.40	2400 bps	O	O
4.80	4800 bps	O	O
9.60	9600 bps	O	O
19.20	19200 bps	O	X
38.40	38400 bps	O	X
57.60	57600 bps	O	X
PRINT	PRINT DATA OUT (PT-100)	-	-

F-11. Auto zero tracking (Auto zero operation range setup)

(Standard setup value : 00)

Display data	Setting
00 } 99	00 : Auto Zero is not used. 01 ~99 : Set up the operation range of auto zero

F-12. Auto zero tracking time (Auto Zero tracking time setup)

(Standard setup value : 0.0)

Display data	Setting
00 } 5.0	0.0 : Auto Zero is not used. 0.1 ~5.0 : Set up the auto zero operation time (0.1 ~ 5.0 sec)

F-13. Force unit (Conversion Unit setup)

(Standard setup value : 0)

Display data	Setting			
0	kg.f		kg/cm ²	
1	N	kgf × 9.8	-	-
2	lb	kgf × 2.2	-	-
3	-	-	Bar	kg/cm ² × 0.98
4	-	-	MPa	kg/cm ² × 0.098

Note) During calibration, set up the unit you want after calibrating it into Kg.

F-14. Key disabling (Front key Locking setup)

(Standard setup value : 0000)

Display data	Setting
<p>0 0 0 0 ←</p> <p>↑ ↑ ↑</p>	<p>Hold key Lock (1), Release (0)</p> <p>Hi key Lock (1), Release (0)</p> <p>Lo key Lock (1), Release (0)</p> <p>Zero key Lock (1), Release (0)</p> <p><Set-up example> 1001 : Zero & Hold key Lock, Hi and Lo key Release</p>

8-3. Digital calibration (Calibration by sensor output value)

At the time of purchasing sensor, the rated capacity (R.C) and rated output (R.O) declared on the calibration sheet can be used for the calibration for easier calibration.

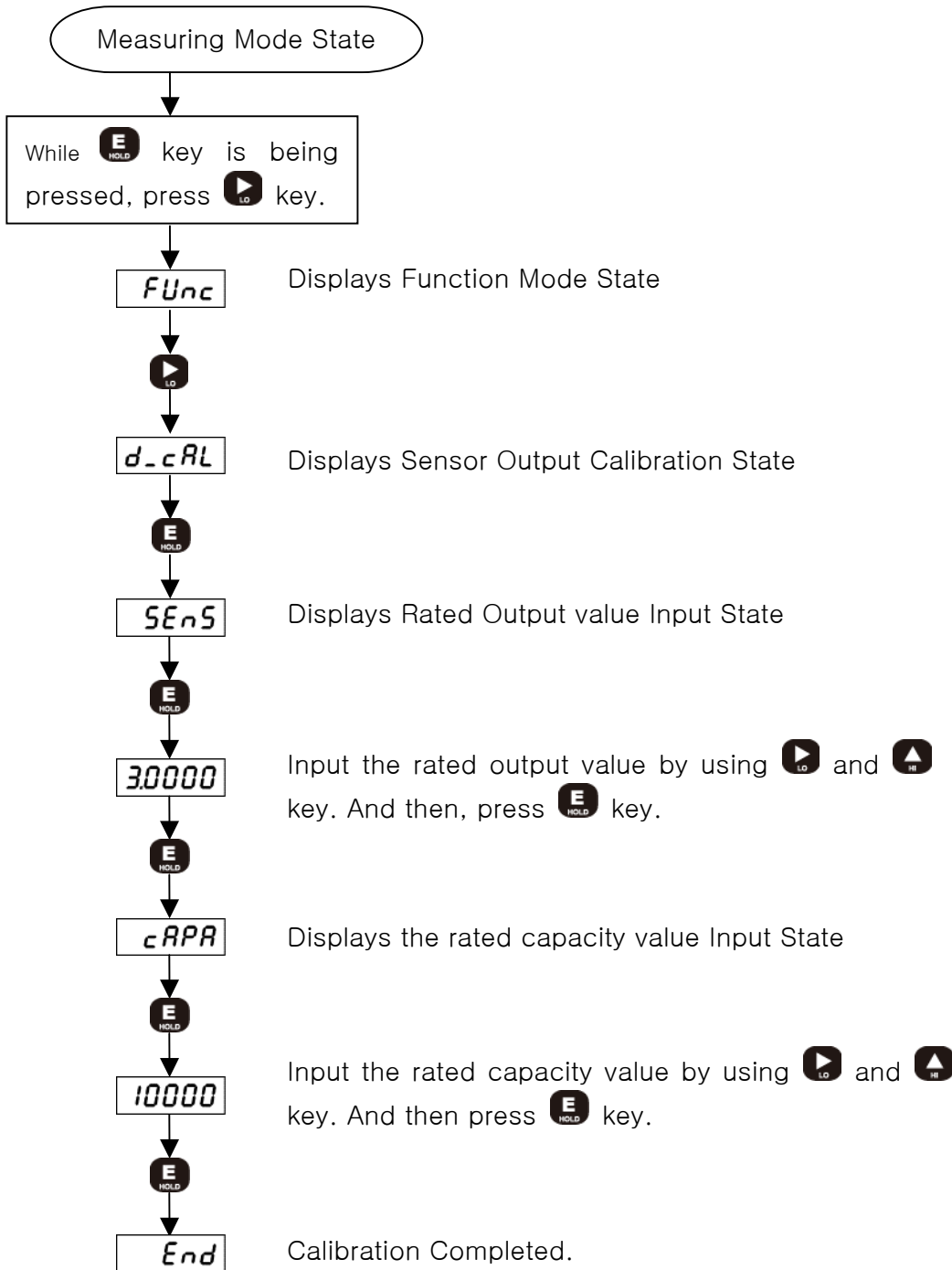

8-4. Actual load calibration

This is a calibration method by adding actual load on the sensor. Standard weight is Needed.

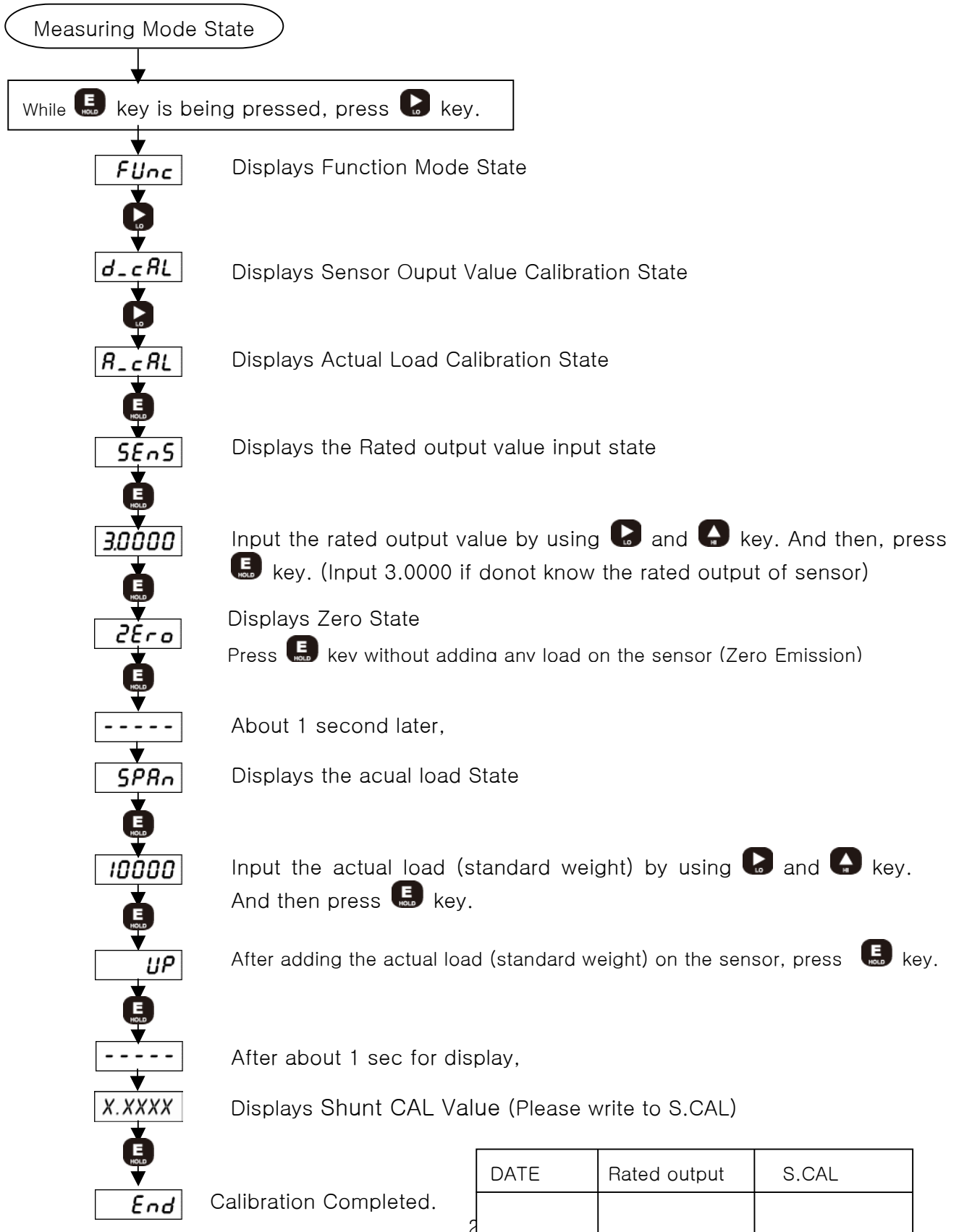

DATE	Rated output	S.CAL

8-5. Calibratuib by Shunt CAL Value

It is to calibrate with the S.CAL value written down for load calibration. You can calibrate without any standard weight.

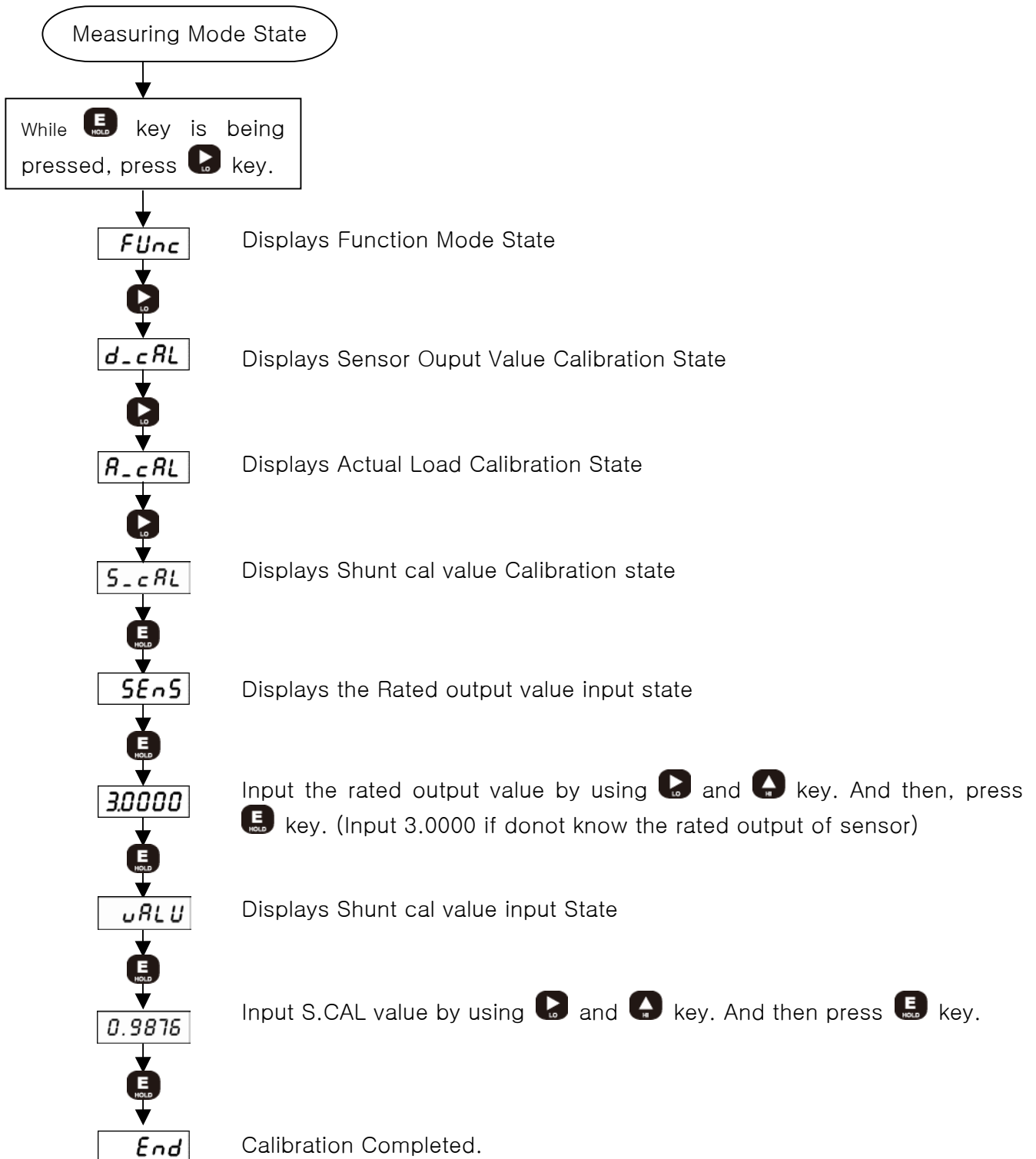

8-6. DATA BACK-UP & RESTORE

You can save all the set-up values of the device and then restore them to the current set-up state as per your need.

- DATA BACK-UP : Save the current set-up state.
- RESTORE : Restore the current set-up state.

1) DATA BACK-UP

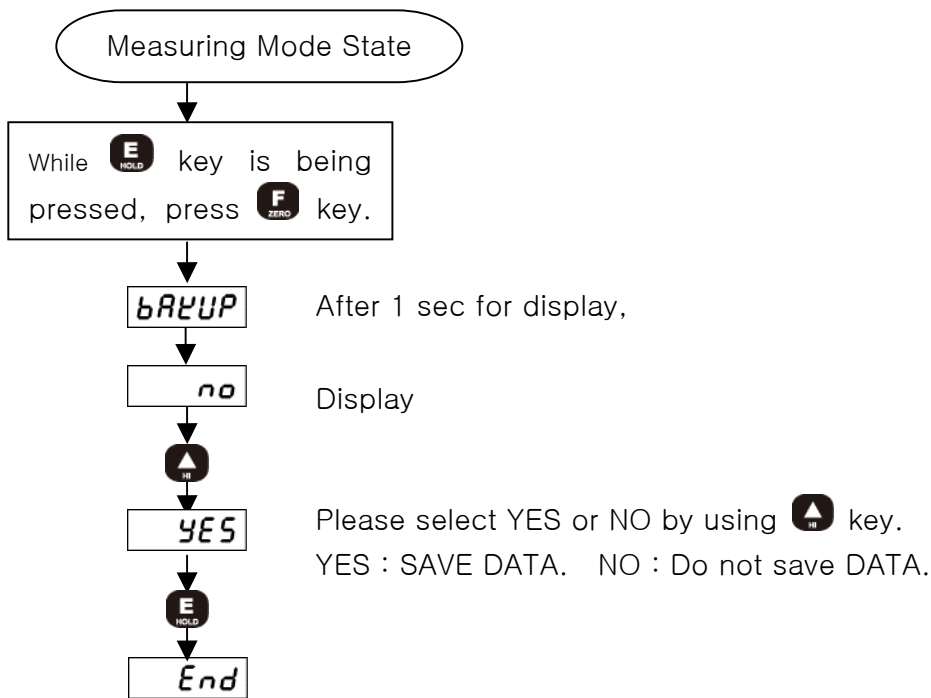

2) RESTORE

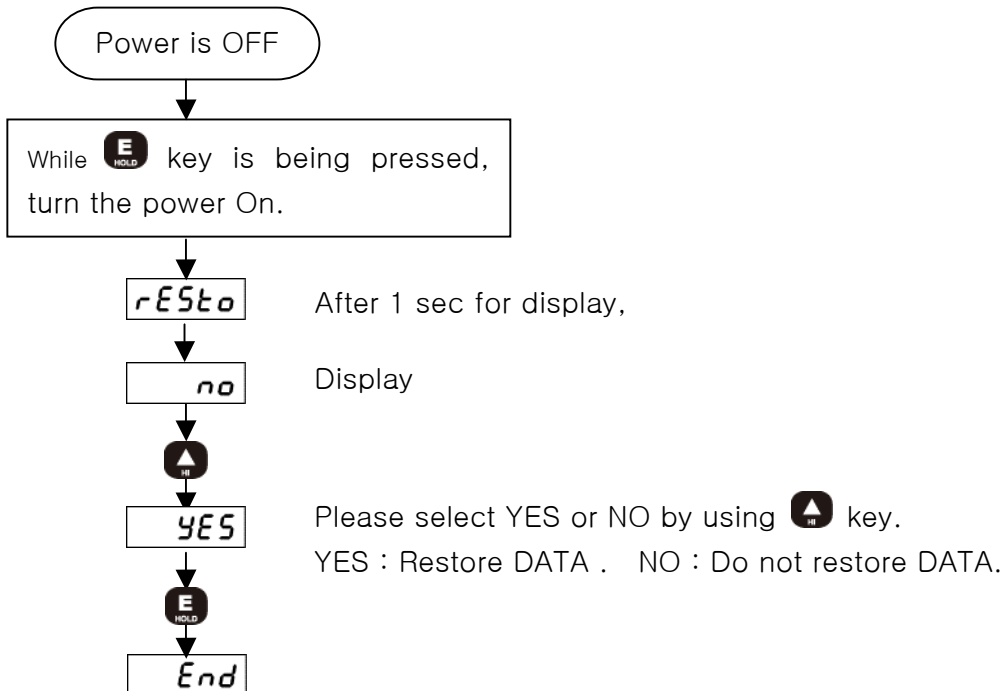

8-7. Lock Set-up

You can prevent any accidental operation due to the unnecessary key control by Lock set-up. After finishing calibration, it is recommended to set the Lock.

At the first stage, please start while the power is OFF.

Related Function when Lock is set : Function related to calibration, DATA BACK-UP

& RESTORE function etc.

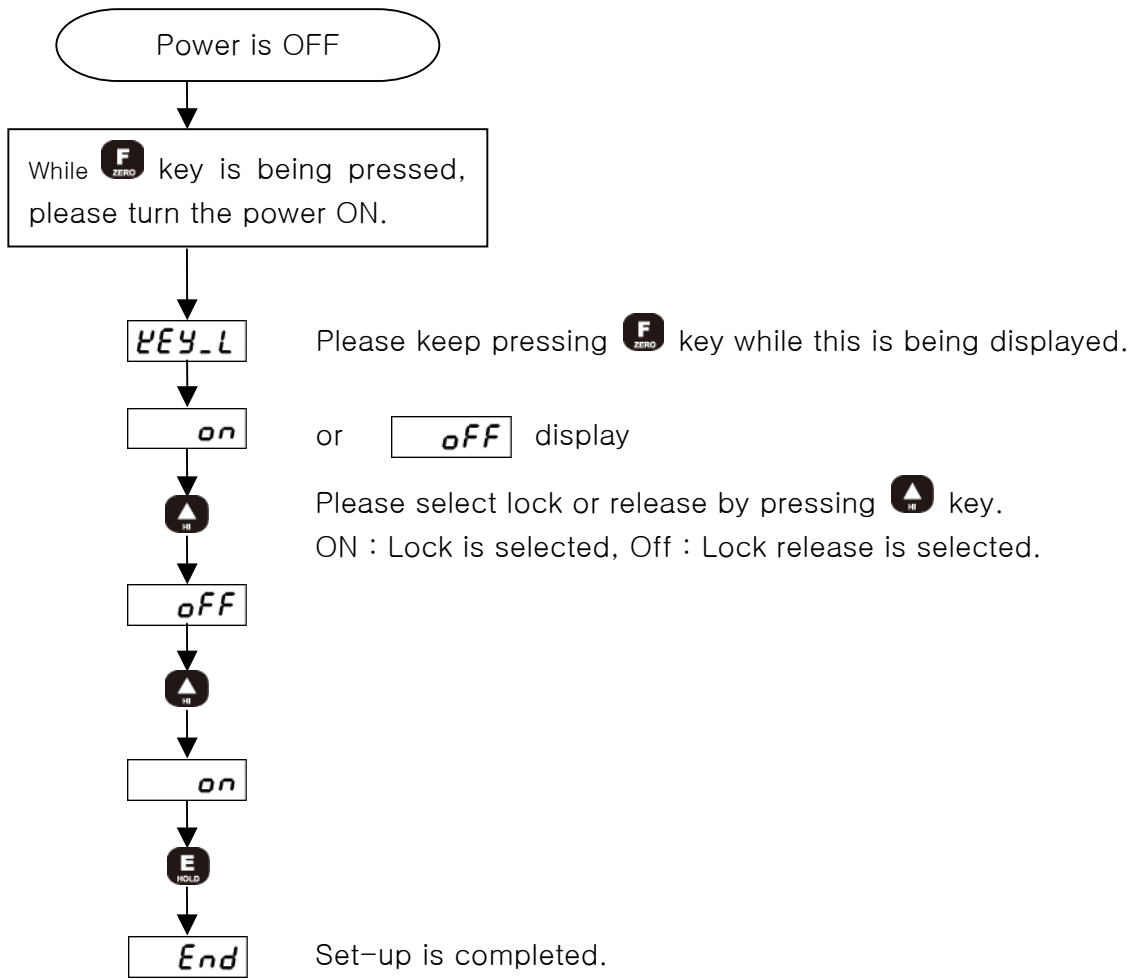

9. Product Inspection

Symptom	Cause	Action	Remark
When Display trembles.	<ul style="list-style-type: none"> • Load cell is damaged. • Load cell insulation resistance. • Indirect occurrence 	<ul style="list-style-type: none"> • Load cell input, output. • Check resistance • Check load cell's insulation resistance. 	<ul style="list-style-type: none"> • Insulation resistance (Cable & Case > 1000 Mohm)
When weight goes up at a regular ratio or zero returns are not made.	<ul style="list-style-type: none"> • Loadcell faulty 	<ul style="list-style-type: none"> • Check load cell's insulation resistance. 	
	<ul style="list-style-type: none"> • Loadcell connection is insufficient. 	<ul style="list-style-type: none"> • Check the wiring between load cell and the main device. • Check the load cell's cable's disconnection. 	
When weight changes into (-).	<ul style="list-style-type: none"> • Loadcell wiring is reversed. 	<ul style="list-style-type: none"> • Check load cell's output cable connection. 	<ul style="list-style-type: none"> • Output : (+SIG) (-SIG)
Displayed as "OVER" or "UNDER"	<ul style="list-style-type: none"> • Load cell is damaged. • Load cell connection is bad. 	<ul style="list-style-type: none"> • Check the load cell's condition and cable connection. 	

10. OPTION

#Option-02 (RS232C)

Since RS232C Interface is very sensitive of electric noise. So please do the wiring from AC Power and electric wires separately. Also you must use the shield cable always.

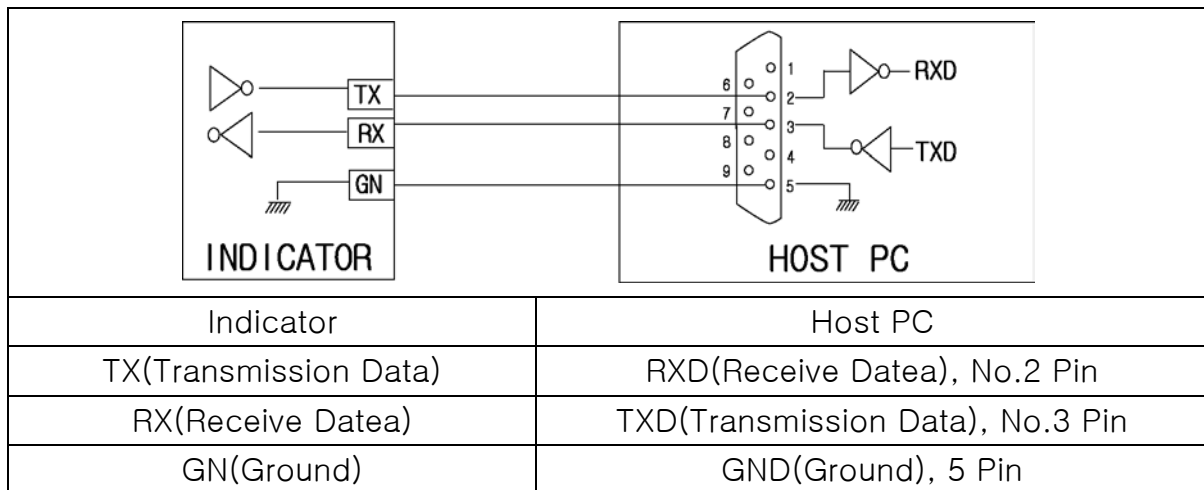

- TYPE : EIA-232C
Method : Half-duplex, asynchronous method.
- Baud-rate : Select one of 2400, 4800, 9600, 19200, 38400, 57600bps
- Parity : No Parity
- Data bit : 8 bit
- Stop bit : 1bit
- Stream mode (Ex. Data +1234.5 transmission)

CODE	BYTE1	BYTE2	BYTE3	BYTE4	BYTE5	BYTE6	BYTE7	BYTE8
ASCII	S	T	,	N	T	,	+	0
HEX	53H	54H	2CH	4EH	54H	2CH	2BH	30H

CODE	BYTE9	BYTE10	BYTE11	BYTE12	BYTE13	BYTE14	BYTE15	BYTE16
ASCII	1	2	3	4	.	5	CR	LF
HEX	31H	32H	33H	34H	2EH	35H	0DH	0AH

1) BYTE1, BYTE2

- . DATA Stable : S T . DATA Unstable : U S
- . DATA OVERFLOW : O L . DATA UNDERFLOW : U L

- 2) BYTE3 ~ BYTE6 : fixed character (, N T ,)
- 3) BYTE7 ~ BYTE14 : DATA 8 BYTE (including +/-)
- 4) BYTE15 : CARRIAGE RETURN
- 5) BYTE16 : LINE FEED

7. Command mode : Please setup as RS485 mode and use.(Refer to OP-03:RS485)

#Option-03 (RS485)

Since RS485 Interface is very sensitive of electric noise. So please do the wiring from AC Power and electric wires separately. Also you must use the shield calbe always.

1. TYPE : RS485
2. Method : Half-duplex, asynchronous method
3. Baud-rate : Select one of 2400, 4800, 9600bps
4. Parity : No Parity
5. Data bit : 8 bit
6. Stop bit : 1bit

Please set up the device No. referring to INDICATOR Manual.

(Can setup from 1 to 32 channel.)

7. Command Form (PC -> INDICATOR)

CODE	BYTE1	BYTE2	BYTE3	BYTE4	BYTE5
ASCII	I	D	0	1	P
HEX	49H	44H	30H	31H	50H

- 1) BYTE1, BYTE2 : Fixed Charactor (ID)
- 2) BYTE3, BYTE4 : Device Number (1 ~ 32)
- 3) BYTE5 : Command Order (P, H, R, Z)

8. Command Chart

Command		Description
ASCII	HEX	
P	50H	Transmit the current value of order equipment.
H	48H	Hold for order equipment.
R	52H	Release hold for order equipment.
Z	5AH	Operate the current value of order equipment as ZERO.

9. Transmission Data Form (INDICATOR → PC)

CODE	BYTE1	BYTE2	BYTE3	BYTE4	BYTE5	BYTE6	BYTE7	BYTE8
ASCII	I	D	0	0	1	,	+	0
HEX	53H	54H	30H	30H	31H	2CH	2BH	30H

CODE	BYTE9	BYTE10	BYTE11	BYTE12	BYTE13	BYTE14	BYTE15	BYTE16
ASCII	1	2	3	4	.	5	CR	LF
HEX	31H	32H	33H	34H	2EH	35H	0DH	0AH

- 1) BYTE1, BYTE2 : Fixed Charactor (ID)
- 2) BYTE3 ~ BYTE5 : Device number (1 ~ 32)
- 3) BYTE6 : Fixed Charactor (,)
- 4) BYTE7~BYTE14 : DATA 8byte (Including +/-)
- 5) BYTE15 : CARRIAGE RETURN
- 6) BYTE16 : LINE FEED